



The CRYO AB LNG fuel tank.

The LNG fuel tank designed for your fuel system.

CRYO AB delivers standardized and customized LNG fuel systems for ferries and other ships. The systems replace marine diesel oil propulsion.

More than 25 delivered systems.

CRYO AB - Development and tradition

CRYO AB
Box 8887, SE-402 72 Gothenburg, Sweden
Phone +46.31.646800, Fax +46.31.532220, www.cryo.se

THE LINDE GROUP

Linde

CRYO AB

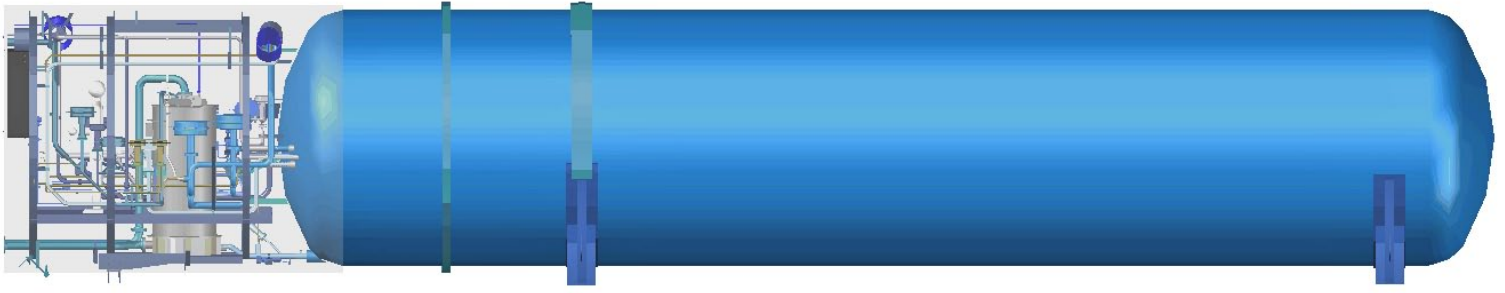

Layout of a LNG fuel tank. The shaded area is inside the enclosed cold box.

Customized to your wishes.

CRYO AB's new LNG fuel systems developed to your wishes and the well known safety standard belonging to a CRYO AB cryogenic tank. CRYO AB ensures with this new LNG fuel system minimal down time and lowest possible fuel emission.

The LNG Fuel System includes:

- One or two LNG Fuel Tanks.
- A Vaporizer unit for vaporization of the LNG to gaseous natural gas.
- A Pressure build up unit for regulation of tank pressure.
- Bunker station with filling and vapour return connection.
- Piping for bunkering and delivery of natural gas to the engines.

TANK DATA			
Volume	Diameter	Length, incl cold box	Weight
115 m ³	4.2 m	~14.5 m	~50 ton
125 m ³	3.6 m	~15.3 m	~55 ton
201 m ³	5.3 m	~15.5 m	~90 ton
234 m ³	5.5 m	~16.5 m	~100 ton

Examples of tank sizes available from CRYO AB.

CRYO AB.

The LNG tank is manufactured by CRYO AB - a leading pressure vessel manufacturer specialized in cryogenic applications. CRYO AB has a wide range of approvals and procedures for quality control, e.g. ISO 9001-certification, ADR-DNV, ASME U-stamp and R-stamp.

Emissions reduction.

The key potential in conversion from marine diesel oils is reduction of emissions. NO_x emission can be reduced by about 90%, while CO₂ by about 20%. Emission of particles will be almost zero and SO_x emissions will be zero.

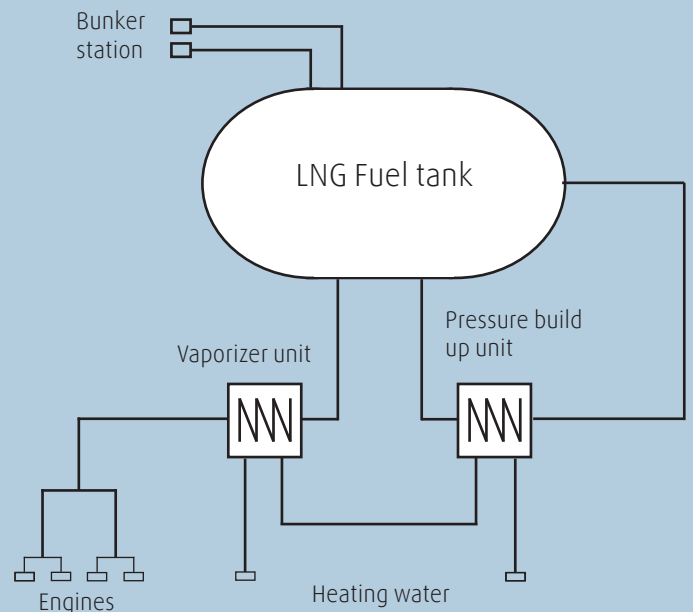

General outline of the LNG fuel system.

CRYO AB

Box 8887, SE-402 72 Gothenburg, Sweden
Phone +46.31.646800, Fax +46.31.532220, www.cryo.se

THE LINDE GROUP

Linde

CRYO AB